



# Grill Guide

For Model BQ04028  
LP Gas Barbecue Grill



## **FOR YOUR SAFETY:**

1. Read this Grill Guide before attempting to assemble or operate your grill.
2. Follow all safety instructions.
3. Check for leaks according to directions in this Grill Guide before operating your grill, even if a retailer assembled this grill.
4. Keep this Grill Guide for future reference.
5. Contact ? 1-800-933-0527 should you need assembly assistance or have any questions.

## **TO THE INSTALLER OR PERSON ASSEMBLYING THIS GRILL:**

Leave this Grill Guide with the grill for future reference.

## **THIS GRILL IS FOR OUTDOOR USE ONLY.**

If stored indoors, then detach and leave propane cylinder outside.

## **POUR UTILIZATION A L'EXTERIEUR SEULEMENT.**

Si Appareil est entrepose a l'intérieur; enlever les bouteilles et les laisser a Pexterieur.

# Safety Precautions

Always read and follow all **DANGER, WARNING, AND FOR YOUR SAFETY** notices in this Grill Guide. Failure to do may result in serious bodily injury or death, or in a fire or an explosion causing damage to property.

1. Grill installation must conform with local codes, or in their absence, with either the National Fuel Gas Code, ANSI Z223.1, or CAN/CGA-B149.1 Natural Gas Installation Code or CAN/CGA-B149.2, Propane Installation Code.
2. Handling and storage of LP cylinders must conform to LP Gas Code NFPA/ANSI 58 or CAN/CGA-B149.2.
3. This gas grill is not intended to be installed in or on recreational vehicles and/or boats.
4. This grill is safety certified for use in the United States and Canada only. Do not modify for use in any other location. Modification will result in a safety hazard.
5. Never use any other type of fuel for this grill other than LP gas.
6. Only use the pressure regulator with a type 1 connector that is supplied with this gas grill.
7. Check all gas hoses for fraying, cracking, or excessive wear. Replace any with those signs before using the grill.
8. Always perform a Leak Test before operating your grill.

## **! FOR YOUR SAFETY !**

1. Do not store or use gasoline or other flammable vapors and liquids in the vicinity of this or any other appliance.
2. An LP cylinder not connected for use shall not be stored in the vicinity of this or any other appliance.

## **! AVERTISSEMENT !**

1. Ne pas entreposer Ni utiliser de l'essence ni d'autres vapeurs ou liquides inflammables dans le voisinage de l'appareil, ni de tout autre appareil.
2. Une bouteille de propane qui n'est pas recordée en vue de son utilisation, ne doit pas être entreposée dans le voisinage de cet appareil ou de tout autre appareil.

## **! FOR YOUR SAFETY !**

If you smell gas:

1. Shut off gas to the appliance.
2. Extinguish any open flame.
3. Open lid.
4. If odor continues, immediately call your gas supplier or your fire department.

## **! AVERTISSEMENT !**

S'il y a une odeur de gaz:

1. Coupez l'admission de gaz de l'appareil.
2. Éteindre toute flamme nue.
3. Ouvrir le couvercle.
4. Si l'odeur persiste, appeler immédiatement votre compagnie de gaz ou votre department des incendies.

## **! WARNING !**

Combustion by-products produced when using this product contain chemicals known to the State of California to cause cancer, birth defects, and other reproductive harm.

# Table of Contents

Safety Precautions.....	2
Table of Contents.....	3
Warranty.....	4
Customer Support Center.....	4
Assembly Instructions.....	5-16
General Information and Operation.....	17-25
Trouble Shooting Guide.....	26-27
Owner Registration Card.....	28-29

---

**Write down here and keep for future reference**

Date of Purchase: \_\_\_\_\_

Serial Number: \_\_\_\_\_

The serial number may be found on the placard located on the back of the grill

**Kmart Corporation**  
**3100 West Big Beaver Road**  
**Troy MI 48084-3163**  
**? 1-248-463-1000**

Visit us at: [www.kmart.com](http://www.kmart.com)

# Limited Warranty

The manufacturer warrants to the **original consumer-purchaser** that this product shall be free from defects in workmanship and materials under normal and reasonable use when assembled and operated according to this Grill Guide from date of purchase as follows:

**Stainless Steel and Die Cast Parts - 99 years**  
**Stainless Steel Burners - 10 years**  
**Remaining Parts – 2 years**

The manufacturer will, at its option, refinish or replace any product or part found to be defective during the limited warranty period. The manufacturer may require you to return the part(s) claimed to be defective for its inspection, freight or postage prepaid. Contact our Customer Support Center as shown below before returning any part(s).

Additional information can be obtained by writing:

**Barbecue Grills  
Warranty Dept.  
1375 Mitchell Blvd  
Schaumburg, IL 60193**

The manufacturer will require reasonable proof of purchase. We strongly recommend you keep your sales receipt and register your grill. You can attach your receipt to this guide.

This limited warranty does not cover the cost of any inconvenience or property damage due to failure of the product and does not cover damage due to misuse, abuse, alteration, improper or failure to perform normal and routine maintenance, discoloration, accident, or damage arising out of transportation of the product. This limited warranty will not apply to any grill used for commercial use.

This limited warranty is the sole warranty given by the manufacturer and is in lieu of all other warranties; express or implied, including implied warranty of merchantability or fitness for a particular purpose. Neither manufacturer dealers nor the retail establishment selling this product have any authority to make any warranties or to promise remedies in addition to or inconsistent with those stated above.

This limited warranty applies only to products sold at retail, and is not transferable.

The manufacturer's maximum liability, in any event, shall not exceed the purchase price of the product paid by the original consumer-purchaser. Some states do not allow the exclusion or limitation of incidental or consequential damages. Therefore, the above limitations or exclusions may not apply to you. This warranty gives you specific legal rights and may also have other rights, which vary from state to state.

## Customer Support Center

Thanks for purchasing a BBQ Pro™ Grill. We're here to help you maximize your enjoyment and appreciation of your new grill. Please don't hesitate to contact us should you have any questions regarding assembly, performance, warranty, or accessories. Please have your model number ready before you contact us. We're here to serve You!

- If you need assistance or to order parts: **Call ? 1-800-933-0527** or send a **FAX to ? 1-847-252-1001.**
- Business hours: **Monday through Friday; 8:30AM-5:00PM Central Time.**
- Visit us on the web at: [www.omahagrills.com](http://www.omahagrills.com)

# Assembly Instructions

This page will give you an overview of information to assemble your grill. The following pages will show in step-by-step detail how to do so. We offer the following suggestions to make your grill assembly as easy as possible.

- 1.) Read through the entire Assembly Instructions before you begin.
- 2.) Choose an area large enough to comfortably lay out all the parts and hardware with enough room to easily maneuver.
- 3.) Have an area with a non-abrasive surface where you can lay parts without scratching them.
- 4.) Use 2 people to remove the Cabinet and Firebox Assembly from the carton. You will also need 2 people to attach the Casters to the Cabinet and Firebox Assembly.
- 5.) Lay all parts and hardware out and ensure you have everything listed on the Parts and Hardware page before you begin assembly. See the Customer Support Page for contact information should any parts be damaged or missing.
- 6.) A Phillips Head Screwdriver has been provided for assembly. You will not need any additional tools.
- 7.) Do not use a Power Screwdriver for assembly as you could strip the threads on the Nuts and Bolts.
- 8.) The propane tank for this grill is sold separately. See the LP Gas and Cylinder Information later in this guide.

## BQ04028

### **! WARNING !**

Failure to follow all Danger, Warnings, and For Your Safety notices in this Grill Guide may result in serious bodily injury or death, or in a fire or an explosion causing damage to property.

### **! CAUTION !**

Perform the Leak Test explained later in this Grill Guide before operating your grill.

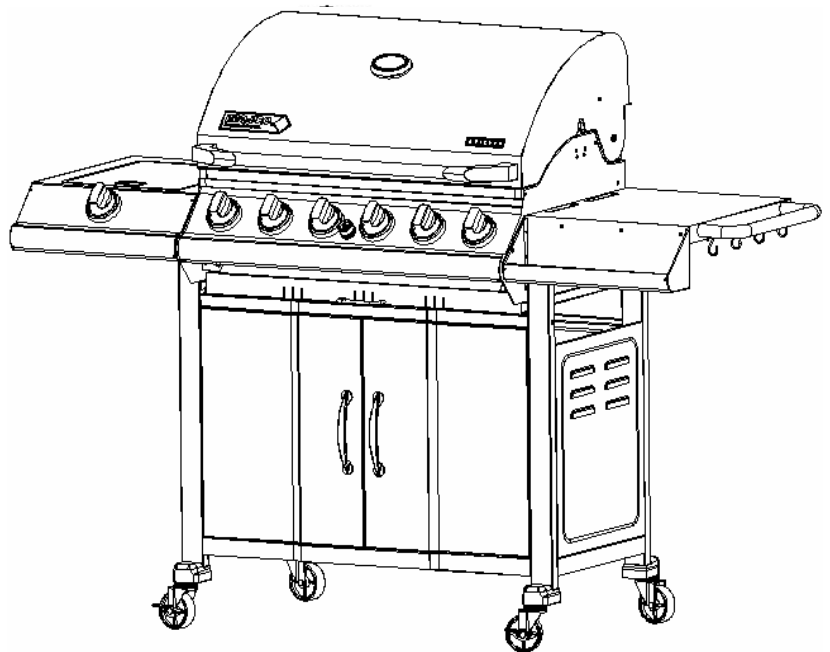

## BQ04028 Detail Parts List

1. Thermometer
2. Thermometer Seat
3. Stainless Steel Lid - Outer
4. Logo Plate
5. Lid Side Panel - Left
6. Silicon Stopper
7. Handle Connector
8. Hood Handle
9. Stainless Steel Lid - Inner
10. Lid Side Panel - Right
11. Name Plate
12. Side Burner Cover
13. Side Burner Cover Support
14. Control Knob
15. Control Knob Seat
16. Side Burner Front Panel
17. Side Burner Valve
18. Side Burner
19. Side Burner Front Bracket
20. Side Burner Inside Frame
21. Side Burner Rear Bracket
22. Side Burner Electrode
23. Side Burner Shelf Frame
24. Pan Support
25. Warming Rack
26. Grease Pan
27. Grease Pan Handle
28. Firebox - Left Side
29. Electrode
30. Burner
31. Main Burner Bracket
32. Firebox - Right Side
33. Cotter Pin
34. Heat Diffuser
35. Cooking Grate
36. Gas Hose
37. Regulator and Hose
38. Firebox - Front
39. Control Panel
40. Firebox - Back
41. Gas Manifold Assembly
42. Electric Igniter
43. Right Side Table
44. "S" Hooks
45. Right Side Table-Hood Handle
46. Condiment Rack
47. Right Side Table Rear Bracket
48. Right Side Table Front Bracket
49. Bottom Heat Shield
50. Heat Shield for Firebox - Inner
51. Heat Shield for Control Panel - Inner
52. Heat Shield for Control Panel - Outer
53. Cylinder Support Ring
54. Manual Igniter
55. Cabinet - Left Side Panel
56. Caster Cap
57. Standard Caster
58. Door Stopper Plate
59. Locking Caster
60. Magnetic Door Stopper
61. Cabinet Door Handle
62. Cabinet Door - Left
63. Cabinet Door - Right
64. Condiment Basket
65. Cabinet - Bottom Shelf
66. Cabinet Crossbar
67. Cabinet - Back Side Panel
68. Cabinet - Right Side Panel



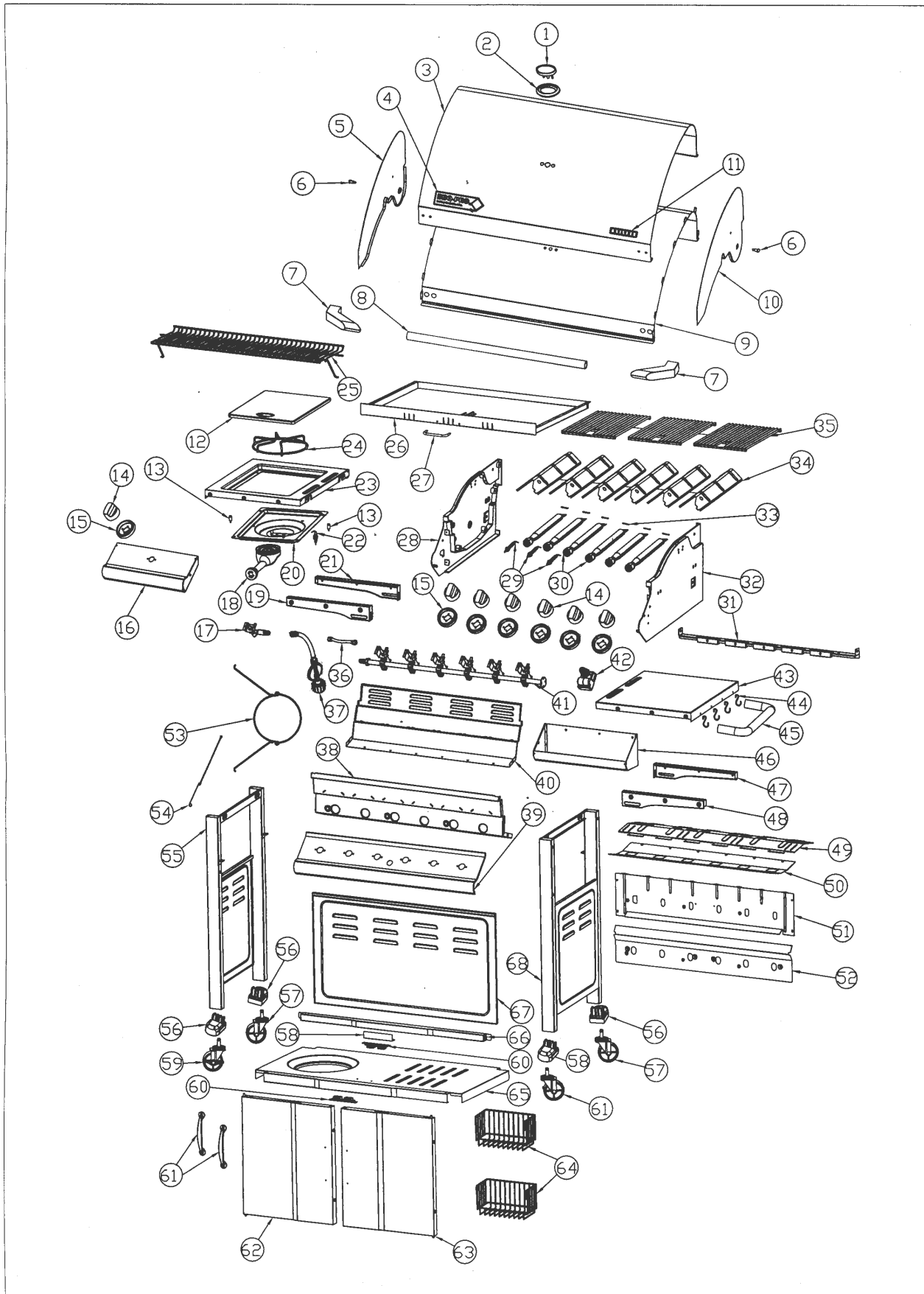





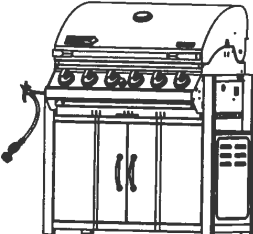
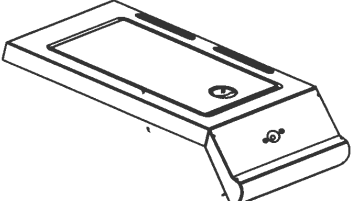
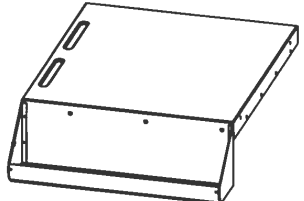
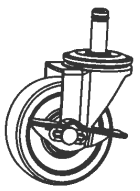
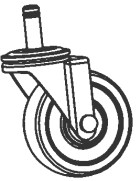
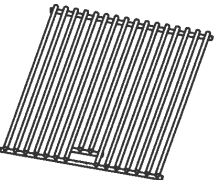
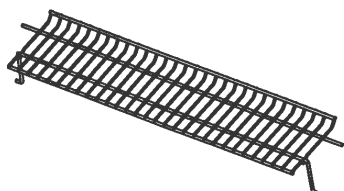
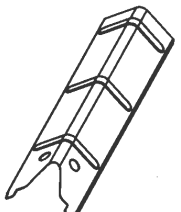
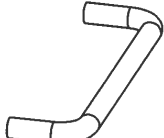
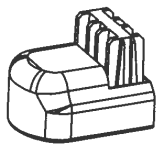



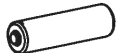

## Parts List

<p>1. Cabinet and Firebox Assembly</p> 	<p>2. Side Burner Assembly....1PC</p> 	<p>3. Side Shelf Assembly....1PC</p> 
<p>4. Locking Casters....2PCS</p> 	<p>5. Standard Casters....2PCS</p> 	<p>6. Cooking Grates....3PCS</p> 
<p>7. Warming Rack....1PC</p> 	<p>8. Heat Diffusers....6PCS</p> 	<p>9. Side Table Handle.....1PC</p> 
<p>10. Caster Caps....4PCS</p> 	<p><b>! WARNING !</b></p> <p>DO NOT DISPOSE OF BATTERIES IN FIRE.</p> <p>BATTERIES MAY EXPLODE OR LEAK.</p>	

## Hardware List

A		Phillips Head Bolt M6*5/8"L	4PCS	F		Control Knob	1PC
B		Phillips Head Bolt M6*3/8"L	4PCS	G		Control Knob Seat	1PC
C		Phillips Head Bolt M4*1/4"L	2PCS	H		Battery Size AA	1PC
D		Lock Washer	8PCS	I		Phillips Head Screwdriver	1PC
E		"S"-Hook	4PCS				

# STEP 1

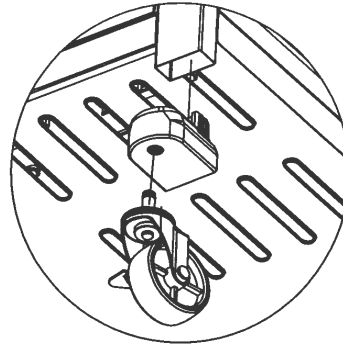
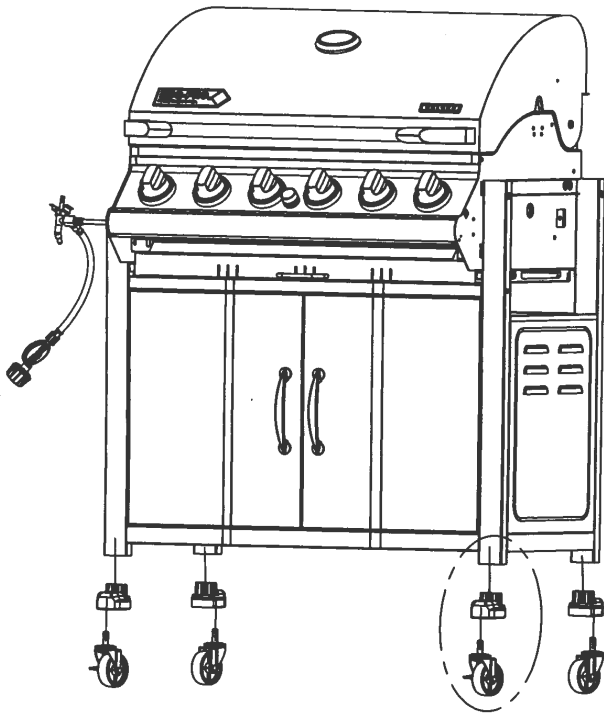

- 1-A Insert Caster Caps (10) into the legs of the Cabinet and Firebox Assembly(1)
- 1-B Insert 2 Locking Casters (4) into 2 Caster Caps (10) in the front legs of Cabinet and Firebox Assembly (1).
- 1-C Insert 2 Standard Casters (5) into 2 Caster caps (10) in the back legs of Cabinet and Firebox Assembly (1).

# STEP 2

2-A Place Side Burner Assembly (2) over the top of the left legs of Cabinet and Firebox Assembly (1) as shown. Ensure the inside edge of the Side Burner Assembly (2) slides down between the firebox and cabinet legs. Also ensure the knob on the right side of the front shelf of Side Burner Assembly (2) slides into its notch on the left side of the control panel as shown in Insert 2.

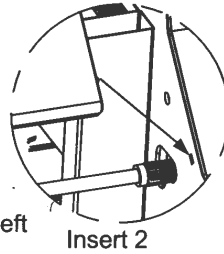

Insert 2

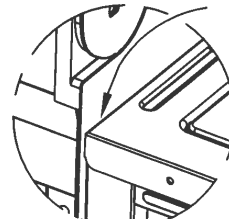

Insert 1

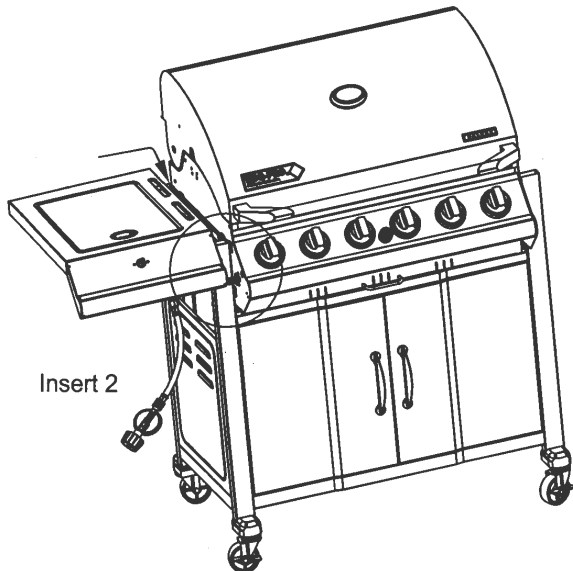

Insert 2

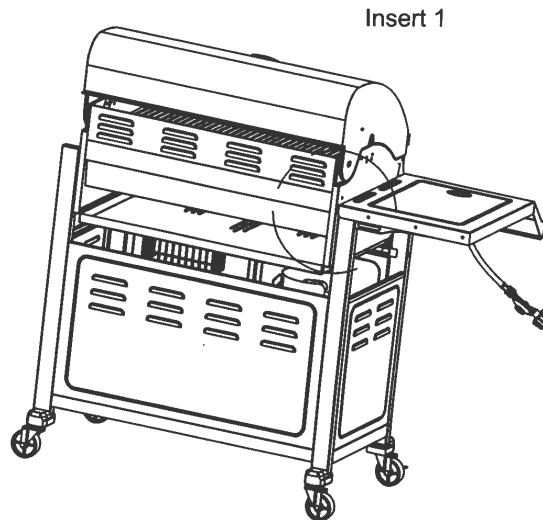

Insert 1

## STEP 3

3-A Attach the Side Burner Assembly (2) to the Cabinet and Firebox Assembly (1) using 2 Phillips Head Bolts (A) and 2 Lock Washers (D) going from the inside of the Firebox and into the Side Burner Assembly as shown in Insert 1.

3-B Continue to attach the Side Burner Assembly (2) to Cabinet and Firebox Assembly (1) using 2 Phillips Head Bolts (B) and 2 Lock Washers (D) going from underneath the Side Burner Assembly and into the Cabinet Legs as shown in Insert 2.

Insert 1

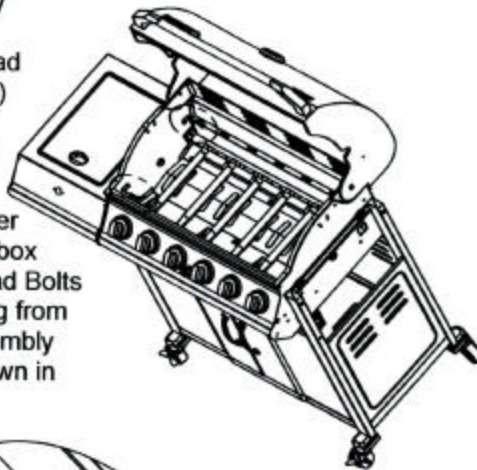

Insert 2

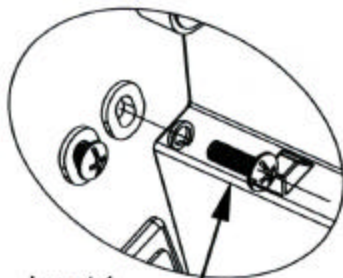
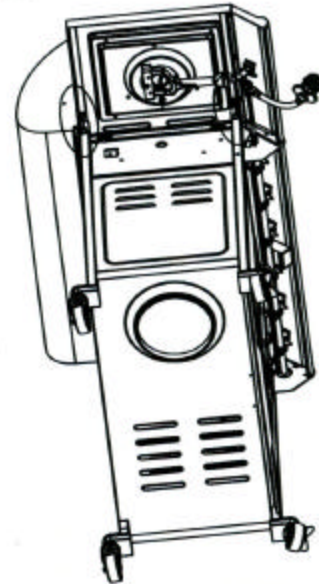

Insert 1

Bolt (A)

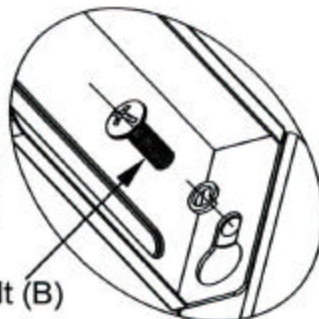

Bolt (B)

Insert 2

Note : Longer Phillips Head Bolts (A) are used to go from inside of the cabinet while the Shorter Phillips Head Bolts (B) are used to go from the underneath side of the side burner assembly.

## STEP 4

4-A Unscrew 2 Phillips Head Bolts(A) and 2 Lock Washers (D) from the Side Table Handle (9) as shown.

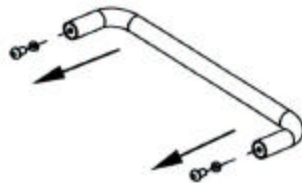

4-B Attach the Side Table Handle (9) to the Side Shelf Assembly (3) using 2 Phillips Head Bolts (A) and 2 Lock Washers (D) as shown.

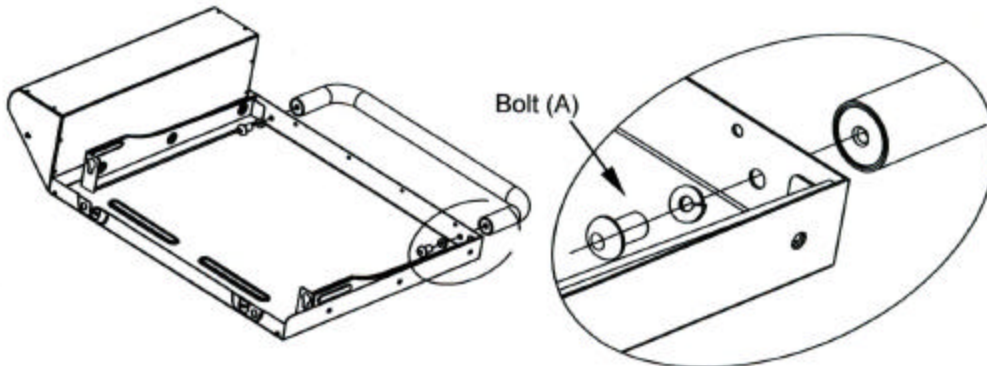

Bolt (A)

## STEP 5

5-A Repeat Steps 2-A, 3-A and 3-B to place and attach Side Shelf Assembly (3) to the Cabinet and Firebox Assembly (1) as shown. Ensure the inside edge of the Side Shelf Assembly (3) slides down between the firebox and cabinet legs. Also ensure the knob on the left side of the front shelf of Side Shelf Assembly (3) slides into its notch on the right side of the control panel.

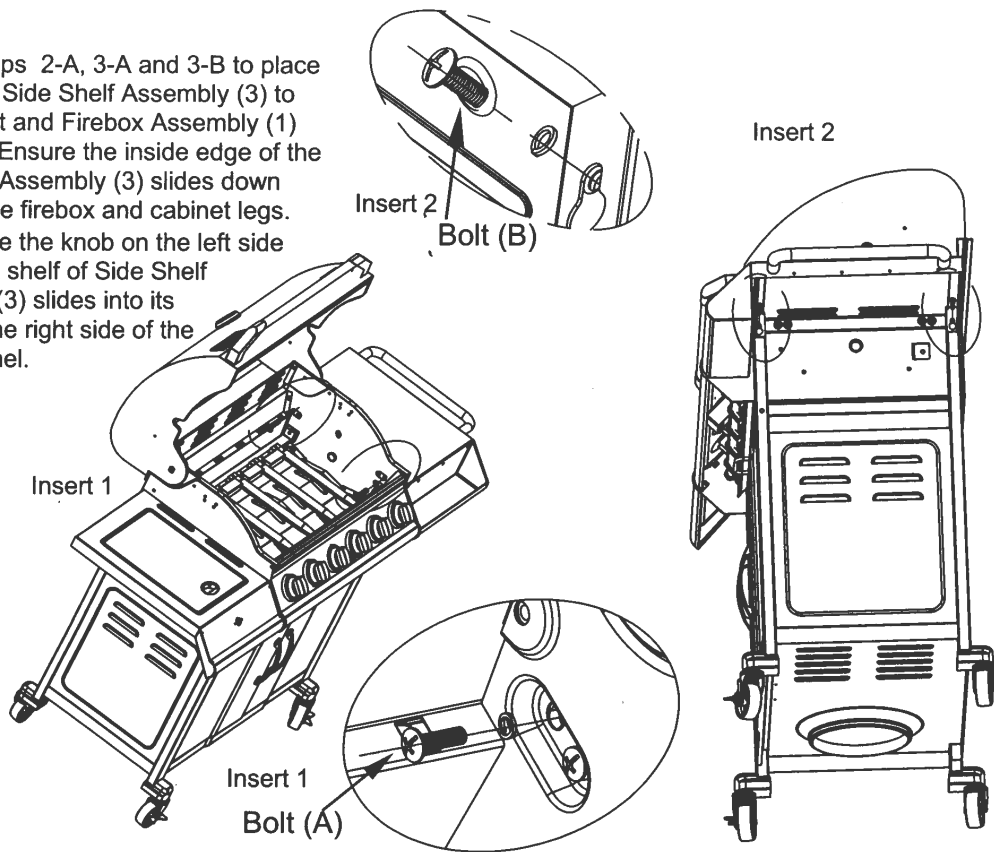

## STEP 6

6-A Insert side burner valve into the side burner. The valve should be centered in the stem tube of the side burner.

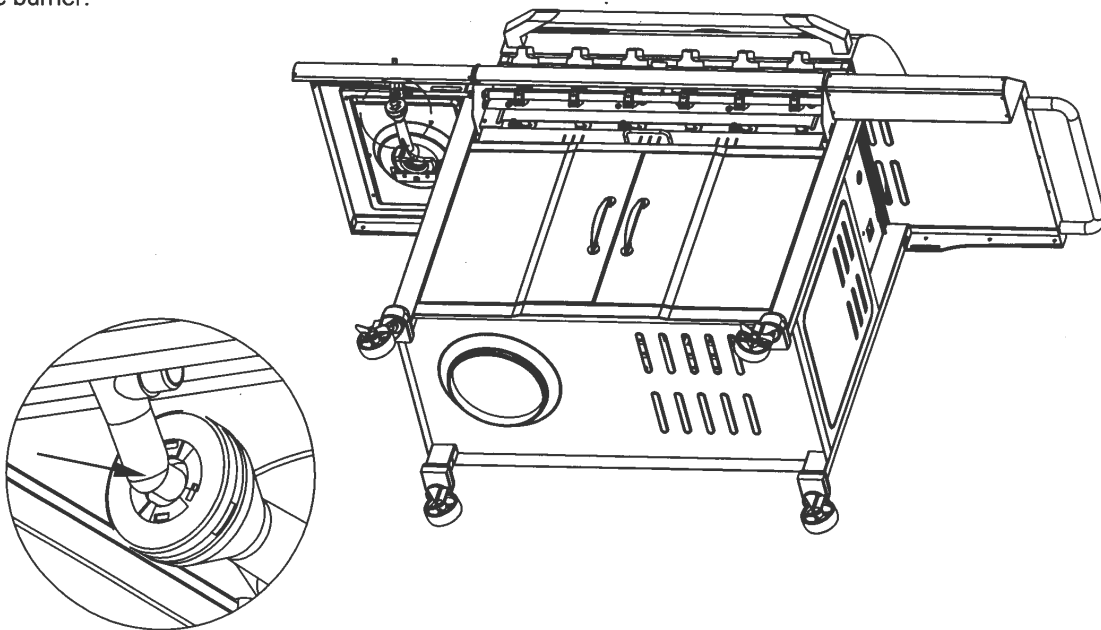

## STEP 7

- 7-A Insert valve stem up through the hole in the side burner front panel from the back side. Place the Control Knob Seat (G) over the valve stem and secure both to the side burner front panel using 2 Phillips Head Bolts (C).
- 7-B Ensure the side burner valve is still centered in the stem tube of the side burner. If not, center, which may involve loosening the 2 Phillips Head Bolts (C) in Step 6-A.
- 7-C Press the Control Knob (F) onto the valve stem.

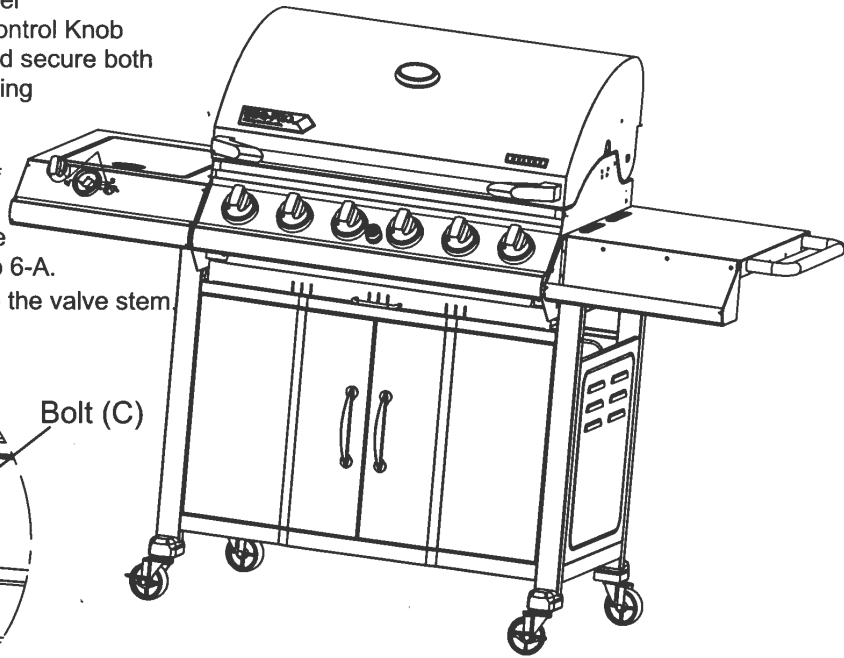
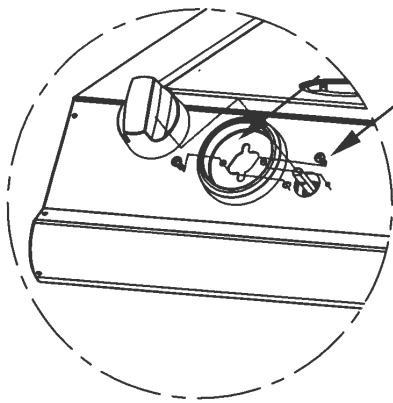

## STEP 8

- 8-A Slide the side burner ignition wire over the side burner igniter connector as shown.

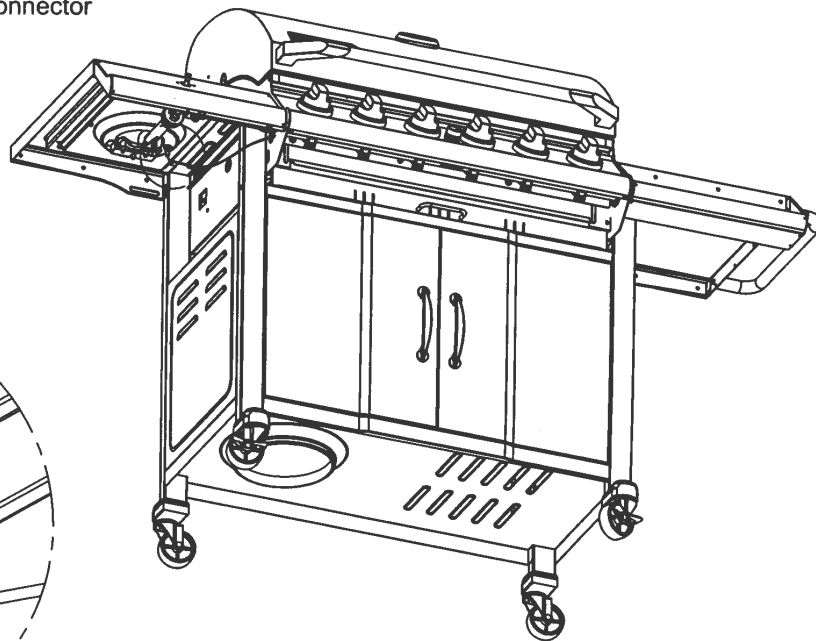
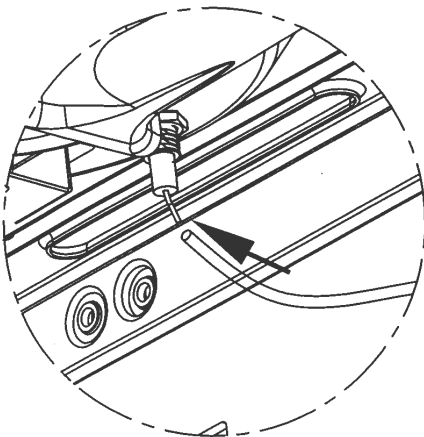

## STEP 9

9-A Place the Heat Diffusers (8) inside the firebox. Ensure the long extensions on the front of the Heat Diffusers (8) go into the appropriate holes at the front of the firebox.

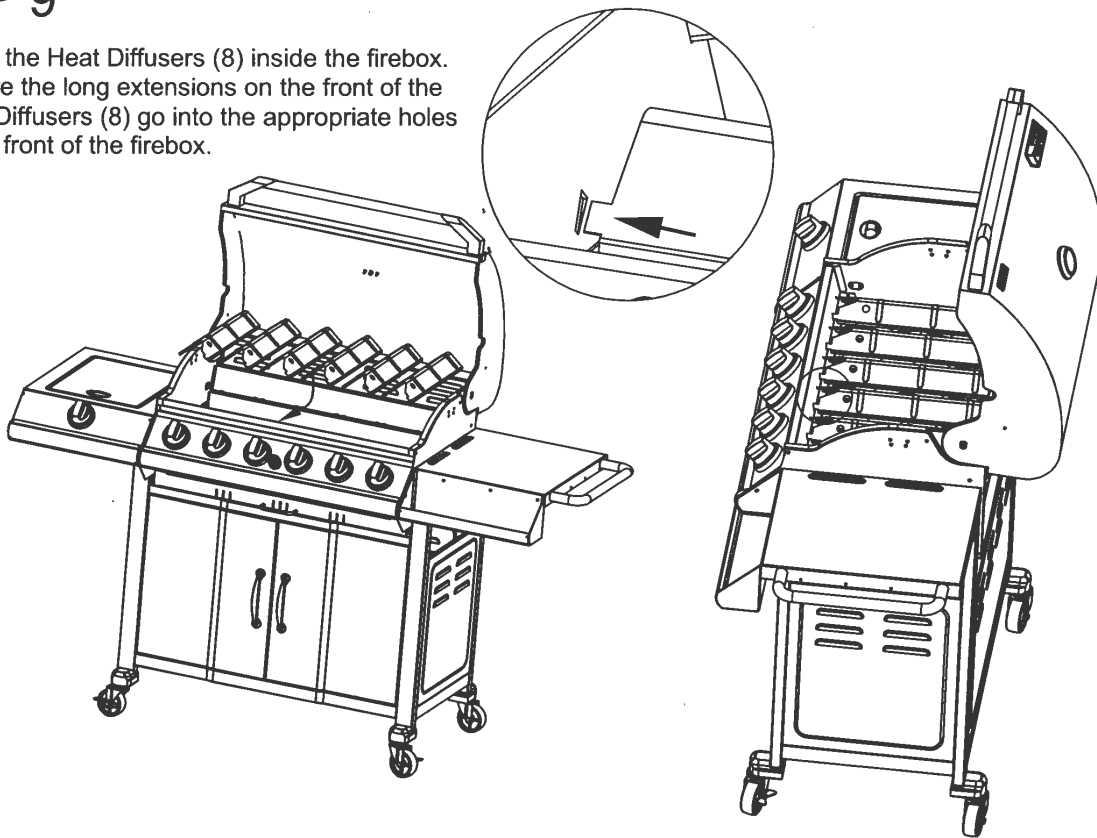

## STEP 10

10-A Insert the Cooking Grates (6) into the firebox.

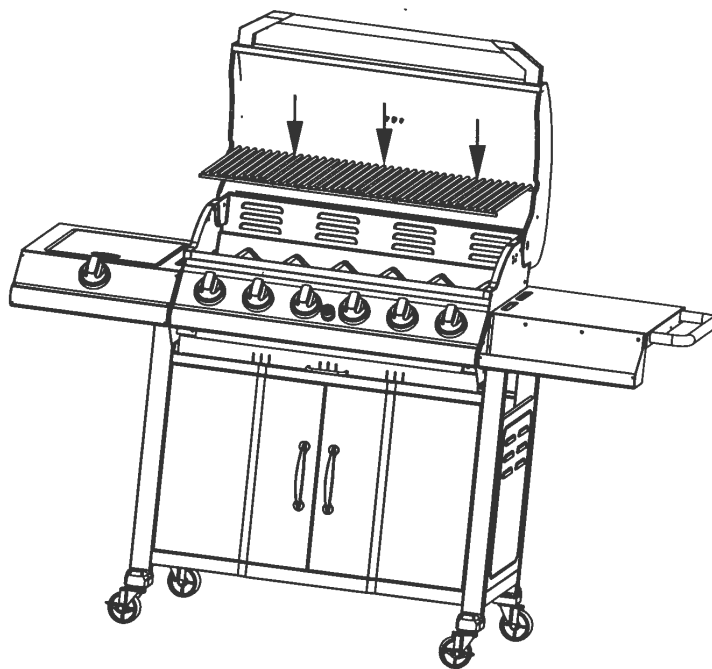

## STEP 11

11-A Insert Warming Rack (7) into the side walls of the firebox and hood as shown. The "L" shaped wire will insert into holes in the sides of the firebox, and the straight wire will insert into holes in the sides of the hood.

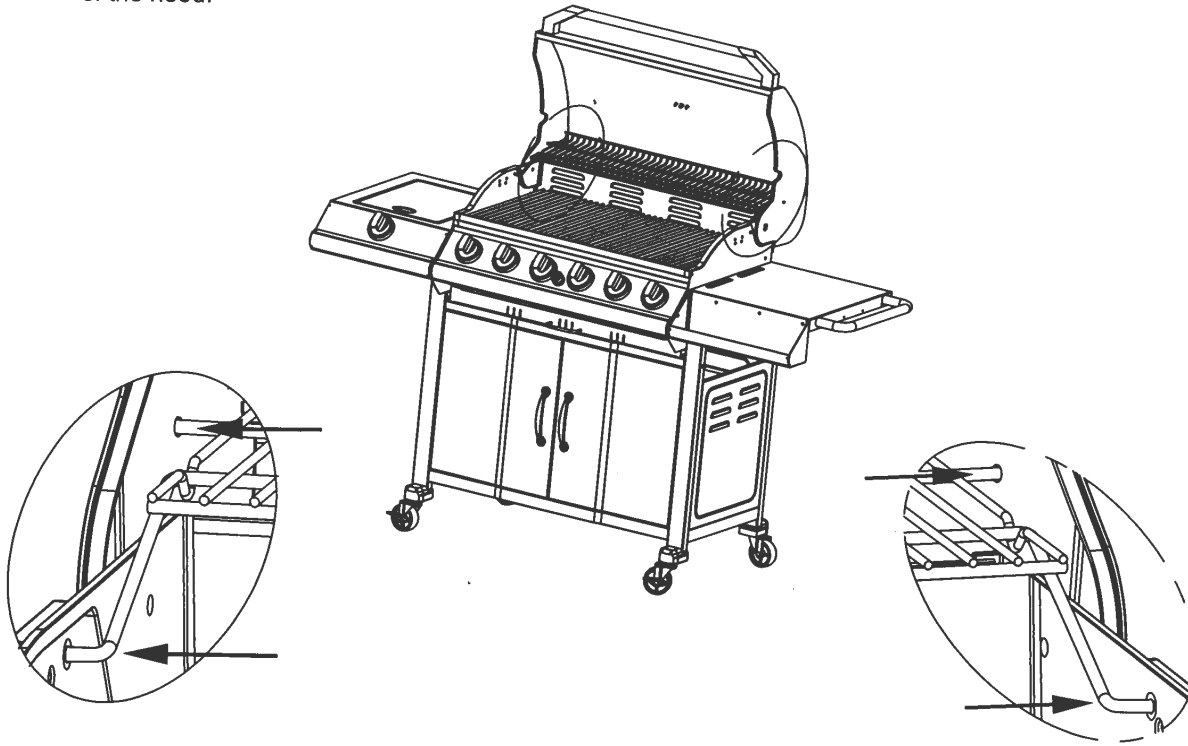

## STEP 12

12-A Insert the "S" Hooks (E) into the side of the Side Shelf Assembly (3) as shown. The smaller end inserts into the Side Shelf Assembly (3) and the larger end will support many Barbecue Tools and Utensils.

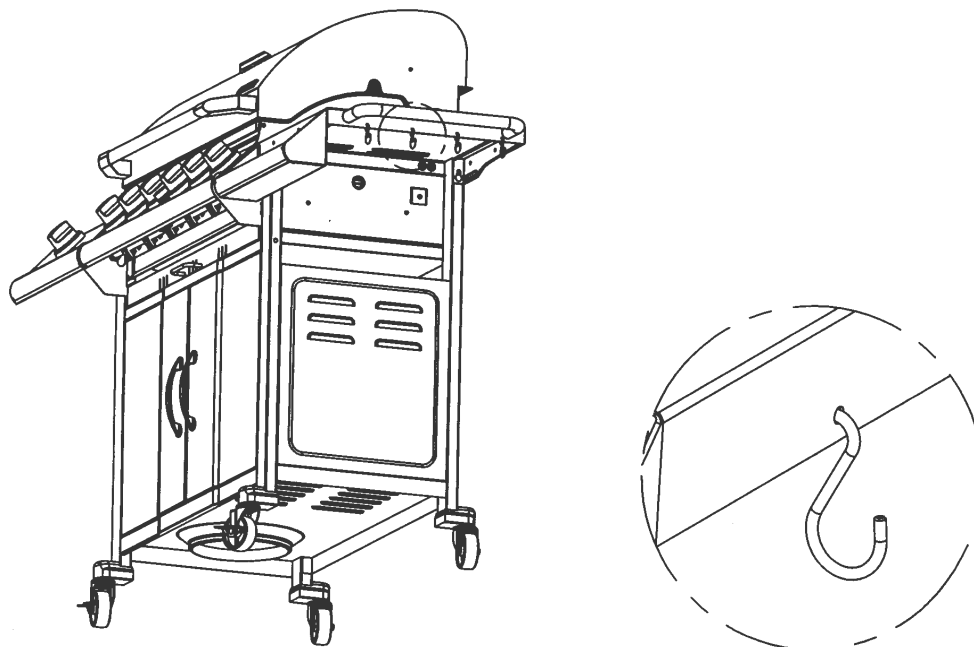

## STEP 13

- 13-A Unscrew the electronic igniter top. Place "AA" battery (H) into the electronic igniter with the Positive (+) end facing up. Screw the electronic igniter top back into place on the electronic igniter.

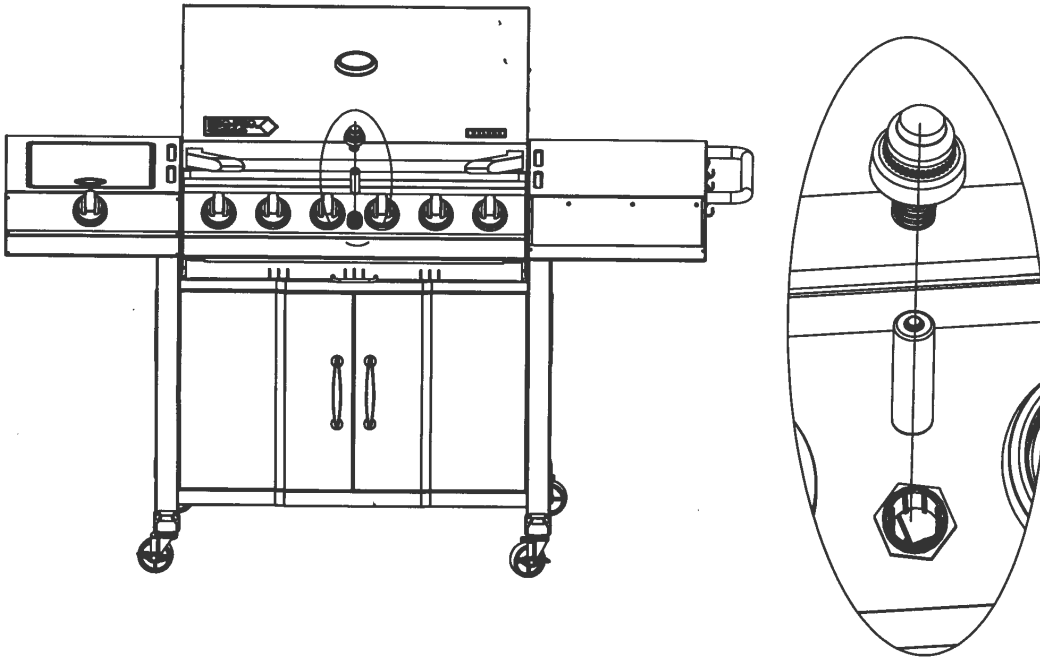

## STEP 14

- 14-A Pull the cylinder support ring up to the top of the cabinet.  
14-B Place the LP cylinder down into the tank support hole in the bottom panel. Ensure the valve faces toward the left panel or front of the cabinet.  
14-C Unhook the LP cylinder Support Ring as shown.  
14-D Lower the LP cylinder Support Ring over the top of the LP cylinder and wrap around the neck of the cylinder. Secure in place using the same hook.

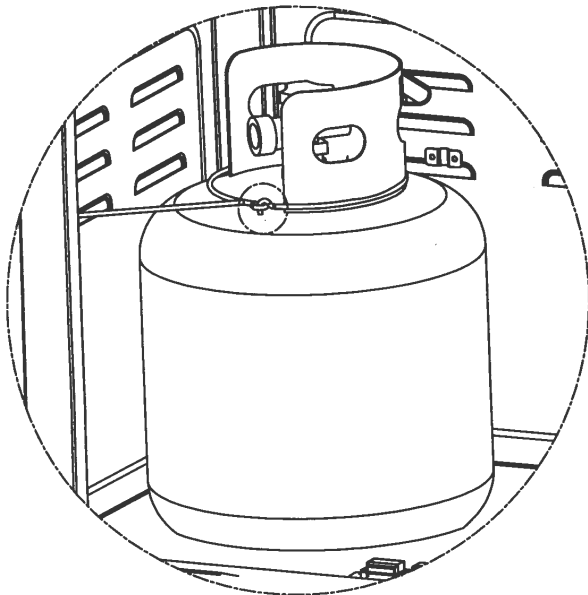

**!WARNING!**  
Do not attempt to hook up the LP cylinder to the regulator at this time.

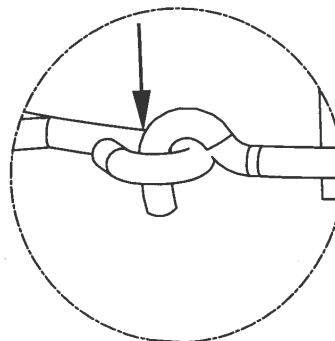



## STEP 15

15-A Remove the 4 labels from the hood, grease tray front, side burner cover, and grate.

15-B Congratulations! Your grill is now assembled. Please proceed to and read the General Information and Operation portion of this Grill Guide before attempting to hook up the LP gas cylinder or operating your grill.

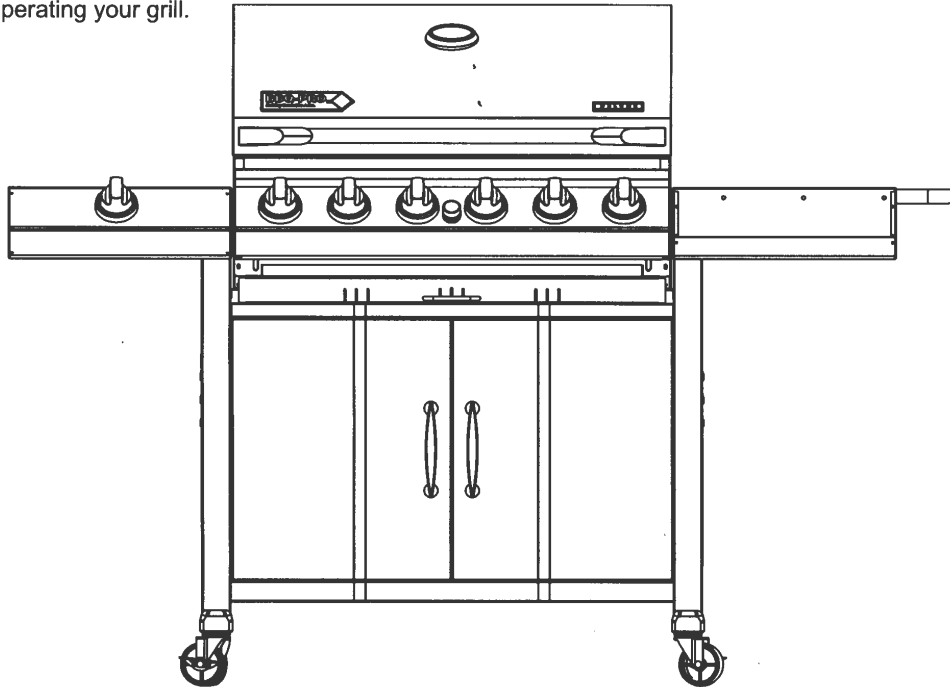

# General Information and Instructions

Your new BBQ Pro™ Grill has been designed and manufactured to high quality standards. It will provide you with many years of enjoyment with a minimal amount of maintenance. Please keep in mind the following **FOR YOUR SAFETY**.

## OPERATION

1. Your gas grill requires reasonable care during operation. It will be hot during cooking and cleaning. You should never leave the grill unattended or move the grill when in use.
2. Children should never use your gas grill. Keep younger children and pets away when in use.
3. Only use your gas grill outside in a well-ventilated area. Never use indoors in any building, garage, shed, or under any type of flammable canopy or overhang.
4. Turn all gas valves off should the burners go out when cooking. Open the lid and wait 5 minutes before relighting.
5. Do not lean over the grill or touch the edges of the firebox or lid when in use.
6. Turn the burners off, close the lid, and shut off the LP cylinder should a grease fire occur.
7. Do not obstruct the flow of combustion and ventilation air to this grill.
8. Keep the outdoor cooking gas appliance area clear and free from combustible materials, gasoline, and other flammable vapors and liquids.
9. Do not put a barbecue cover or other flammable material in the storage area of this grill.
10. Do not use charcoal briquettes or lava rock in this grill.
11. Do not install or use on or in a recreational vehicle and/or boats.

## LP Gas and Cylinder Information

Your new gas grill operates on LP (Liquid Petroleum) Gas. It is odorless, colorless, and non-toxic when produced. You can smell LP gas as it has been given an odor similar to rotten cabbage for your safety.

Your grill uses the newest and safest LP Gas Cylinder.

1. O.P.D. (Overfill Protection Device) – prevents accidental gas leaks caused by overfilling of the tank. Each tank contains a float that closes the input valve when the tank is 80% full. This allows room for the LP gas to expand in hot temperatures. A triangular hand wheel distinguishes this type of tank.
2. O.C.C.1 Type 1 Quick Connect Valve – provides fast tank hook-ups and requires only to be tightened by hand.

Triangular Hand Wheel

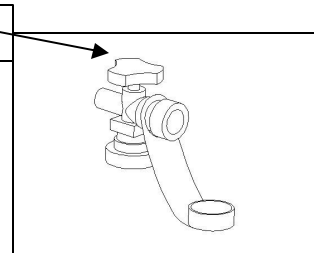

In addition, the LP tank you use with your grill must meet the following requirements

1. Required Measurements: 12-1/2" (317mm) in diameter and 18-1/2" (472mm) in height.
2. 20-pound (9.1kg) propane cylinder.
3. Constructed and marked with U.S. Department of Transportation (D.O.T.) for the US or CAN/CSA-B339, Cylinders, Spheres and Tubes for Transportation of Dangerous Goods; and Commission, for Canada.
4. Type 1 Valve Outlet – distinguished by large external threads on the outlet part of the valve.
5. O.P.D. listed above.
6. A safety release valve.
7. A means for vapor withdrawal.
8. A collar to protect the tank valve.
9. A bottom ring for mounting.

### **! WARNING !**

1. Do not attempt to use a cylinder with any other type of connection device.
2. Do not attempt to use a cylinder with a larger capacity

### **LP CYLINDER FILLING AND EXCHANGE**

Some areas only allow you to exchange your empty cylinder for a replacement that is already full. Other areas allow you to refill your cylinder. If you are in an area where you can refill your cylinder:

1. Use only a licensed dealer.
2. The dealer must first purge a new cylinder before filling.
3. Never fill a cylinder more than 80% full by volume. Volume will vary by temperature. An empty cylinder weighs approximately 18 pounds (8.2kgs). A full one approximately 38 pounds (17.3kgs).
4. Be sure the LP dealer checks the cylinder for leaks after filling.
5. Do not release LP gas into the atmosphere, as it can unexpectedly ignite when mixed with air.
6. Contact a LP dealer to remove LP gas from a cylinder.

Only exchange your cylinder for one with an O.P.D. feature as shown above.

### **! WARNING !**

A frosty cylinder valve indicates possible gas overfill. Close the LP valve and call your dealer immediately.

### **! WARNING !**

1. Never store any extra cylinders near your grill.
2. Keep cylinders out of direct sunlight and high heat.
3. Never fill your cylinder over 80% full by volume. This may cause release of gas from the safety release valve.
4. Immediately call your LP dealer or fire department should you hear, smell, or see escaping gas from the cylinder.
5. Do not insert any type of foreign objects into the valve outlet.

The gas supply must be turned off at the LP-gas supply cylinder when this outdoor cooking gas appliance is not in use.

L'alimentation du gaz doit être fermée a la bouteille de gaz de pétrole liquéfié, lorsque cet appareil de cuisson extérieure u'est pas utilise.

### **LP CYLINDER LEAK TEST**

A leak test should be done each time a cylinder is refilled or exchanged. Do not smoke or use any type of flammable material in the area during this leak test. Do not use an open flame to check for leaks.

1. Test outside in a well ventilated area.
2. Use a paintbrush and a solution of 50% liquid soap and 50% water. Do not use cleaning agents and they can damage the fuel supply parts.
3. Brush liquid onto areas highlighted with arrows.
4. Bubbles indicate a leak.

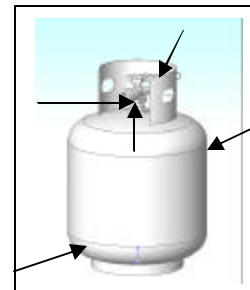

## DANGER

Bubbles indicate a leak. In that case, call your LP dealer or fire department immediately.

### TRANSPORTATION AND STORAGE

1. Always use the Safety Cap when transporting or storing your cylinder.
2. Do not store in a building, garage, or other enclosed area.
3. Always store your cylinder outside.
4. Store out of reach of children.
5. Always transport in an upright position.
6. Do not smoke when transporting your cylinder.

Safety Cap

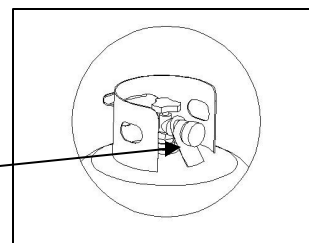

## Regulator and LP Cylinder Connections

### ! CAUTION !

The gas pressure regulator provided with this outdoor cooking appliance must be used. This regulator is set for an outlet pressure of 11 inches water column.

### ! MISE EN GARD !

Le régulateur de pression de gaz prévu avec cet appareil de cuisson a gaz pour l'extérieur doit être utilisé. Ce régulateur est réglé pour une pression de sortie de 11 pouces de colonne d'eau.

Your regulator is equipped with a Q.C.C. Type 1 quick connect system. It will not allow gas to flow until a positive seal has been made. It has a thermal element that will shut off the gas flow if the temperature reaches 240 degrees F (115 degrees C). It also has a flow-limiting device that will restrict the flow of gas to 10 cubic feet per hour (0.28 cubic meters per hour).

### TO CONNECT THE CYLINDER TO THE REGULATOR AND HOSE

1. Be sure the LP cylinder is "OFF" by turning the hand wheel clockwise until it stops.
2. Place the cylinder into the base cabinet shelf of the grill with the valve facing outward. See Assembly Instructions to secure.
3. Be sure all burner controls are turned to the "Off" position.
4. Remove the safety cap from the from the cylinder valve.
5. Center the nipple of the regulator into the cylinder valve
6. Turn the black nut clockwise until it stops. **Hand Tighten Only. Do Not Use A Wrench.**

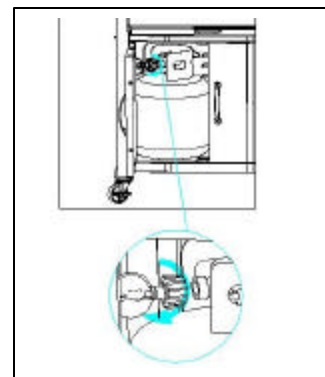

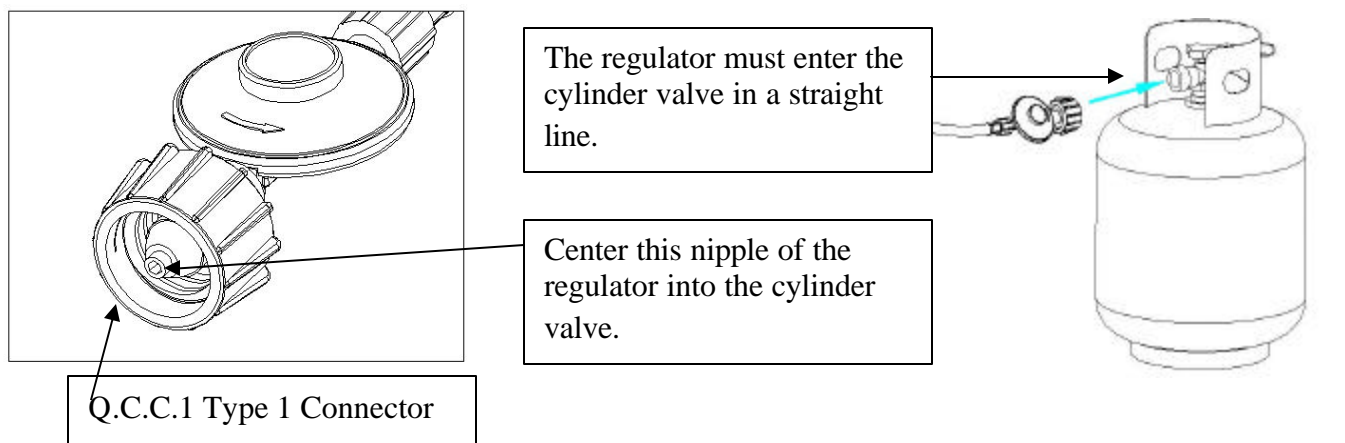

### **! WARNING !**

1. Do not connect this grill to any unregulated sources of propane.
2. Protect the regulator fitting from damage when disconnected. A damaged regulator fitting may result in a gas leak when connected to a LP cylinder.
3. Inspect the gas hose before each use. Replace the hose assembly before use if you notice any fraying, cracking, or excessive wear.
4. Always perform the Leak Test listed below before using your grill for the first time, if the cylinder has been changed, any gas components have been changed, the regulator flow-limiting device has been activated, or after a long period of non-use.
5. Do not attempt to connect this grill to the LP system of a motor home or trailer.

### **LEAK TESTING THE REGULATOR, VALVES, HOSES, AND CONNECTIONS**

1. Ensure the LP cylinder valve and all burners are “Off”.
2. Ensure the LP cylinder is connected to the regulator.
3. Mix up a solution of 50% water and 50% liquid dish soap. Do not use any household cleaner solution.
4. Open the LP tank valve by turning the hand wheel counterclockwise one turn. If you hear a rushing sound, turn the gas off immediately. In that case, there could be a leak at the connection. Reconnect the cylinder to the regulator.
5. Spray or brush on the solution covering the following areas: cylinder welds, regulator and cylinder connection, gas hose connections to the regulator, all gas hoses, all gas hose connections to the burners including the main and side burners.
6. Growing bubbles on any of the parts and connections listed above indicate a gas leak. Immediately shut off the LP tank valve by turning the valve clockwise. Retighten the connections or order replacement parts as needed. Continue to test as necessary until no leaks are detected.
7. Close the LP tank valve by turning the hand wheel clockwise.

### **! WARNING !**

1. **DO NOT USE THE GRILL** if you cannot stop the leaks. Be sure the LP cylinder valve is closed. If the LP cylinder is still leaking, contact your LP dealer or local fire department.
2. Do not use any match or open flame, or smoke, during leak testing.
3. Do not light a burner during leak testing.

## Grill Placement

### ! FOR YOUR SAFETY !

1. Minimum clearance from sides and back of unit to adjacent combustible construction below top of unit, 24 inches (60 cm) from sides and 24 inches (60 cm) from back.
2. Do not locate this outdoor cooking gas appliance under overhead-unprotected combustible surfaces.

### ! AVERTISSEMENT !

1. Dégagement minimal à respecter entre les cotés et l'arrière de l'appareil et une construction combustible adjacente située au-dessous de la partie supérieure de l'appareil, soit 24 pouces (60 cm) des cotés et 24 pouces (60 cm) de l'arrière.
2. Il est interdit d'installer le présent appareil au-dessous des surfaces

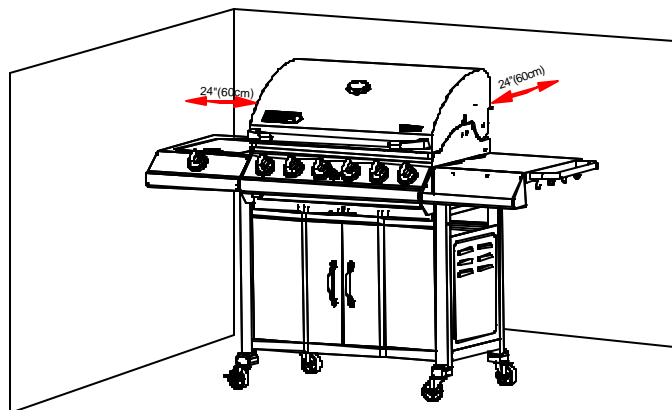

### APARTMENT RESIDENTS

Check with your apartment manager regarding your regulations for barbecues.

### ! WARNING !

1. Do not use this grill in any enclosed area, garage, shed, or under any type of overhead structure or canopy.
2. Operate this grill only in a well-ventilated area.

## Grill Operations

### LIGHTING

Always visually inspect your grill before lighting. Replace any hoses that are frayed or cracked before lighting your grill. Look for anything that may be blocking spaces for ventilation and remove. After lighting, always check the flame to ensure you have a good flame all along each burner. If not able to light, or the flame is not even along the entire burner(s), then see the Trouble Shooting section.

### ! WARNING !

1. Read instructions before lighting.
2. Open lid during lighting.
3. If ignition does not occur in 5 seconds, turn the burner control(s) off, wait 5 minutes and repeat the lighting procedure

### ! ADVERTISSEMENT !

1. Lire les instructions avant d'allumer l'appareil.
2. Ouvrir le couvercle avant d'allumer l'appareil.
3. Si l'appareil ne s'allume pas immédiatement, fermer le robinet du brûleur, attendre 5 minutes puis procéder de nouveau à l'allumage.

## LIGHTING THE MAIN BURNERS USING ELECTRONIC IGNITION

1. Open the lid.
2. Ensure all burner control knobs are in the “Off” position.
3. Turn on the LP gas by turning the hand wheel on the cylinder valve.
4. Turn one burner control knob marked with an igniter flame “” to “High”.
5. Depress the electronic ignition button and hold down. You should hear a clicking sound, which shows the electronic ignition is working.
6. If the burner does not light within 5 seconds, turn the burner control knob to “Off”. Wait 5 minutes for the gas to clear, and repeat the above procedure. Use the Manual directions if it still will not light.
7. When lit, turn the control knob to the desired setting.
8. Your grill is equipped with continuous ignition. Simply turn the control knob of the burner next to the lit burner to HI. It will light automatically. Do not press the electronic ignition button again. Then adjust control knob(s) to desired settings.

## MANUALLY LIGHTING THE MAIN BURNERS WITH THE MATCH LIGHTING STICK

1. Open the lid.
2. Ensure all burners are in the “Off” position.
3. Turn on the LP gas.
4. Place a match in the Match Lighting Stick. This is located on the left side of the grill cabinet underneath the side burner shelf.
5. Strike the match, and insert into the lighting hole close to the burner.
6. Turn the left burner control knob to “High”.
7. If the burner does not light within 5 seconds, turn the burner control knob to “Off”. Wait 5 minutes for gas to clear, and try again.
8. When lit, turn the control knob to the desired setting.

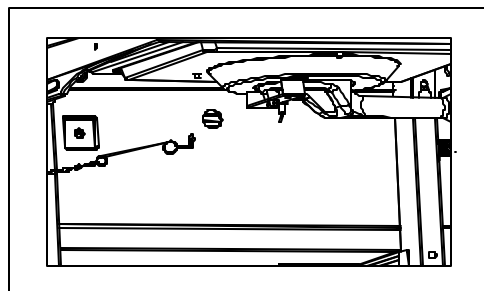

## LIGHTING THE SIDE BURNER WITH ELECTRONIC IGNITION

1. Open the side burner cover
2. Ensure the side burner control knob is in the “Off” position, as well as any main burners not in use.
3. Turn on the LP gas if it is not already on.
4. Turn the side burner control knob to “High”.
5. Depress the electronic ignition button and hold. You should hear a clicking sound, which shows the electronic ignition is working.
6. If the burner does not light within 5 seconds, turn the burner control knob to “Off”. Wait 5 minutes for the gas to clear, and repeat the above procedure. Use the Manual directions if it still will not light.
7. When lit, turn the side burner control knob to its desired setting.

## LIGHTING THE SIDE BURNER WITH THE MATCH LIGHTING STICK

1. Open the side burner cover.
2. Ensure the side burner control knob is in the “Off” position, as well as any main burner not in use.
3. Turn on the LP gas if it is not already on.
4. Strike the match, and place near the top of the burner.
5. Turn the side burner control knob to “High”.
6. If the burner does not light within 5 seconds, turn the burner control knob to “Off”. Wait 5 minutes for the gas to clear, and try again.
7. When lit, turn the side burner control knob to its desired setting.

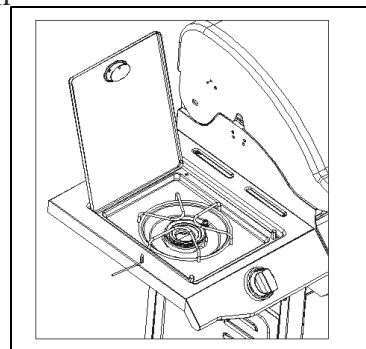

## TURNING OFF YOUR GRILL

1. Turn off the gas supply at the LP tank by turning the valve clockwise.
2. Turn all burner control knobs to the “Off” position.

# Cleaning Your Grill

## **! WARNING !**

1. Do not clean any part of your barbecue grill in a self-cleaning oven.
2. Do not use oven cleaners, abrasive kitchen cleaners, cleaners that contain citrus products, or mineral spirits.
3. Do not use any type of steel bristled brush.
4. Clean your grill regularly to prohibit grease build-ups and avoid a grease fire or excessive flare-ups.

**STAINLESS STEEL** – clean with multipurpose low abrasive non-phosphorous metal or stainless steel polish and a soft cloth. Always polish in the direction of the lines. Do not allow grease and dirt to accumulate.

**OTHER EXTERIOR SURFACES**– wash with a mild dish soap and warm water. A cloth, soft brush, or plastic cleaning pad can be used. Rinse thoroughly and wipe dry.

**COOKING GRATES, WARMING RACK, AND HEAT DIFFUSERS** – use a stiff brass brush. Wash with warm water and mild dish soap as needed, rinse, and dry.

**GREASE PAN AND TRAY** – check after each use. Remove and empty the Tray when half full. Remove and clean the Pan as grease builds up. Both can be washed with warm water and mild dish soap.

**ELECTRONIC IGNITER** – visually inspect for cracks. Replace if a crack is found. Do not use water to clean the igniter.

**BURNERS** – we recommend you clean your burners at least twice a year, or before use if the grill has not been used in over one month.

## **! WARNING !**

Small insects, such as spiders, are able to access the burner tubes. Sometimes they will build nests or spin webs. In either case, this can block or reduce the amount of gas flowing through the burner. You will usually see a smaller flame, or a flame that is mostly yellow rather than blue, coming from the burner when this happens. Other signs include the grill not heating evenly, not reaching temperature, or burners not igniting. In cases with severe blockage, this can cause the flame to burn backwards, and outside of the burner tubes, which can cause damage to your grill and/or personal injury. **IMMEDIATELY SHUT OFF THE FLOW OF LP GAS AT THE CYLINDER BY TURNING THE HAND WHEEL CLOCKWISE SHOULD THIS HAPPEN.** Wait for the grill to cool, and then clean all burners.



## CLEANING THE BURNERS

1. Ensure the LP gas is turned off at the LP cylinder.
2. Remove the cooking grates, heat diffusers, and grease tray.
3. Remove the cotter pins located underneath the back end of each burner.
4. Lift each burner up and out.
5. Clean the inside of the burner using a stiff wire. A straightened coat hanger is one suggested tool. An alternative way to clean the inside of the burner is using compressed air. Always wear eye protection if using this method. **Never enlarge the burner ports during cleaning.**
6. Brush the outer surface of the burner.
7. Ensure all ports (holes) are free of all debris
8. Inspect the burner. Replace if any cracks or enlarged holes.
9. Reinstall the burners making sure the burners seat over the valves as shown in the figure to the right.
10. Secure the back of the burners to the firebox with the cotter pins.
11. Replace the grease tray, heat diffusers, and cooking grates.
12. Perform a Leak Test described earlier in this guide.

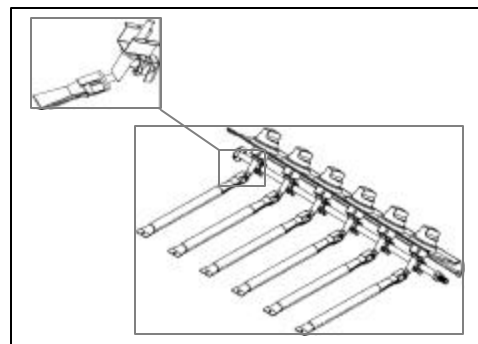

## ELECTRONIC IGNITION MAINTENANCE

Your grill is equipped with electronic ignition. It's powered by one "AA" size battery. Replace the battery when necessary. Unscrew the igniter top. Place the new battery into the igniter with the positive (+) end of the battery facing up. Screw the igniter top back into place.

## GRILL STORAGE

1. Clean your grill before storage.
2. Disconnect the LP cylinder from the regulator. **DO NOT BRING THE LP CYLINDER INDOORS UNDER ANY CIRCUMSTANCES.**
3. Cover the grill.
4. Perform a Leak Test before use after storage.

## Grilling With Your New Grill

Welcome to the world of grilling. Whether you're already an established griller, or just starting out, your new grill should bring you much enjoyment and satisfaction, to say nothing of some phenomenal meals. We encourage you to experiment to find your own favorite recipes.

Your temperature control knobs are labeled "High", "Low", and "Off". Simply push in on the temperature control knobs and turn to the desired heat setting. A thermometer is placed in the hood so that you can see the cooking temperature inside the grill.

The heat diffusers are designed to help evenly distribute heat throughout the grill. They are also designed to catch and smoke the right amount of drippings, adding more flavors to your meal.

## DIRECT VS. INDIRECT COOKING

Food cooked on the grill is either done using direct or indirect cooking. Direct cooking is when the food is cooked directly over the heat. Food is placed in-between the burners for indirect cooking.

## **DIRECT**

1. Used to sear meats. After searing, some food will finish cooking using the indirect method.
2. Usually used for quicker cooking foods.
3. Turn all burners to “High” and close the hood to cook, placing food directly over the heat source.

## **INDIRECT**

1. Used for foods that take longer to cook, including large cuts of meat, such as roasts and ribs.
2. Used for more delicate food that can dry out quickly, such as fish and poultry.
3. Used when cooking fattier foods, as there are less flare-ups.
4. Used when cooking with a roasting pan or aluminum foil.
5. Use any number of burners depending on the model of grill and amount of food, and do not place food directly over any heat source.

## **SIDE BURNER**

Use the side burner to boil soups, corn on the cob, lobster, steam, stir-fries, or warm.

## **GRILLING TIPS AND TRICKS**

1. Always “Preheat” your grill before cooking. Light all main burners, turn to “High”, and close the lid. The thermometer will reach about 550 degrees, which should take about 4 minutes. Then adjust the burner control knobs to the proper temperature. Note that no preheating is necessary for the side burner.
2. We recommend you cook with the lid down. This provides more even circulation of the heat, and the food cooks faster. Remember that heat is lost each time the hood is raised.
3. Mother Nature can impact your grilling times. Allow more cooking time for cold, wind, and higher altitudes. We recommend you place the grill in an area protected from much wind.
4. Trim away any excess fat from meat to reduce flare-ups.
5. Keep similar size portions together so that they cook more evenly.
6. Generally speaking, the more food on the grill, the longer the cooking time.
7. Be aware when using the Direct cooking method, as food can easily become overcooked, burned, or dry out. Food may require more turning, or sometimes, may need to be moved off the flame.
8. Larger pieces of meat generally require more cooking time per pound than smaller pieces of meat.
9. If a major flare-up, or too many flare-ups occur, turn off the gas, move the food away from the flare-up, and close the hood. Restart the grill once the flare-up has died down.
10. Turn foods infrequently. Generally, only turn a steak once during cooking.
11. Use tongs rather than a fork when turning the food on the grill. Less juice will be lost that way.
12. Apply sauces during the latter stages of cooking.
13. A timer can help you keep from over-cooking the food.
14. Use a meat thermometer to be sure the food is properly cooked.
15. Use insulated protective mitts or potholders when working around a grill in operation.
16. Use a small amount of cooking oil on the cooking grates before heating to reduce foods sticking on the grates.

## **FOOD SAFETY**

1. Always use safe food handling and preparation when using this grill.
2. Wash all poultry, seafood, and vegetables before cooking.
3. Use separate platters, plates, and utensils for uncooked and cooked foods.
4. Leave all meat, poultry, and seafood in the refrigerator until ready to cook.
5. Use a meat thermometer to ensure foods are adequately cooked.

# Trouble Shooting Guide

## **BURNER WILL NOT LIGHT**

- 1.) Gas supply is turned off. Turn on gas at LP cylinder.
- 2.) Out of propane. Check to be sure you still have propane in your tank.
- 3.) Regulator is not properly seated into the tank valve. Remove and reattach. Hand tighten only.
- 4.) Crimped fuel supply hose. Inspect and straighten.
- 5.) Regulator failure or damaged hose. Order replacement part and replace.
- 6.) Make sure you can hear the electronic igniter clicking. If not, replace the battery with an “AA” size. Inspect the electrode to be sure it’s not coated in grease or dirt. If so, clean with rubbing alcohol. Check the distance from the electrode tip to the burner. The tip of the electrode should be 1/8” to 1/4” from the main burner and 1/8” to 3/16” from the side burner. Adjust if necessary. Inspect the electrodes to be sure they are not cracked or broken. If so, order replacement parts and replace.
- 7.) Blockage in the gas system. Inspect the venturi tubes to be sure insects, spider webs, etc do not block them. Clean if necessary. Inspect under the control panel to be sure the venturi tubes are aligned properly with the valves.

## **IRREGULAR FLAME OR YELLOW FLAME**

- 1.) New burner may have residual oil, which will burn off.
- 2.) Venturi tubes in burners are blocked. Remove and clean.
- 3.) Burners have a high grease or dirt build-up. Remove and clean.
- 4.) Venturi tubes are not aligned properly with the valves. Inspect under the control panel.

## **SUDDEN DROP IN GAS PRESSURE OR FLAMES BLOW OUT**

- 1.) Out of gas. Check to be sure you still have propane in your tank.
- 2.) Your excessive fuel flow valve has tripped, thereby reducing the flow of gas. Turn off all burners, wait 30 seconds, and relight grill. If problem persists, turn off all burners. Disconnect regulator from tank. Reconnect regulator and leak test. Turn on LP tank and relight grill. Other ways the flow limiting device can be activated include
  - a. A ruptured gas hose. Inspect, perform a leak test, and replace as necessary.
  - b. Opening the control knobs before turning on the LP gas at the cylinder. Turn on the gas at the LP cylinder first before turning on a control knob to light.
  - c. Improper purging of cylinder before it was filled. See your LP gas dealer.
- 3.) Wind could be blowing out your burners. Turn front of grill to face wind or move out of the wind.

## **EXCESSIVE FLARE-UPS**

- 1.) Heat diffusers, inside of grill, grates, and burners need to be cleaned.
- 2.) Grease tray needs to be cleaned and emptied.
- 3.) Using too high of heat to cook. Reduce control knob setting.
- 4.) Direct cooking method will produce more flare-ups than indirect. If using direct method, try using indirect.

## **FIRE BEHIND CONTROL PANEL**

Immediately shut off cylinder valve and allow grill to cool.

- 1.) Check venturi tubes for obstructions and clean.
- 2.) Inspect under the control panel to be sure the venturi tubes are aligned properly with the valves.

- 3.) Gas is leaking from a faulty connection or damaged hose. Perform a leak test and inspect for leaks. Tighten or replace parts as necessary.

## Customer Support

**PHONE: 1-800-933-0527**

**Hours 8:30am to 5:00 pm Central time**

**FAX: 1-847-252-1001**

**WEBSITE: <http://www.omahagrills.com>**

**MAIL: Customer Support – Barbecues  
1375 Mitchell Blvd.  
Schaumburg, IL 60193**

## Product Registration Card

Thank you for purchasing a BBQ Pro™ Grill. Please complete and return the Registration Card or visit us online to register your grill.



1. First Name: \_\_\_\_\_ Middle Initial: \_\_\_\_\_  
Last Name: \_\_\_\_\_

2. Address: (number and street) \_\_\_\_\_ Apt: \_\_\_\_\_  
City: \_\_\_\_\_ State: \_\_\_\_\_ Zip Code: \_\_\_\_\_ Country: \_\_\_\_\_

3. Phone Number Daytime: \_\_\_\_\_

4. Email Address: \_\_\_\_\_

5. Date of Purchase: Month: \_\_\_\_\_ Day: \_\_\_\_\_ Year: \_\_\_\_\_ 6. Purchase Price \$ \_\_\_\_\_ 0 0

7. Name of Store: \_\_\_\_\_

8. What Model Did You Purchase?  
 BQ04022  BQ04023  BQ04024  BQ04025  BQ04026  BQ04027  BQ04028

9. Serial Number: \_\_\_\_\_

Register online at [www.omahagrills.com](http://www.omahagrills.com)

### How to Register Your Product:

1. Visit us on the web at <http://www.omahagrills.com>
- 2.) Complete the above card and mail to:

Warranty Registration  
BBQ Pro Grills  
1375 Mitchell Blvd.  
Schaumburg, IL 60193

You can locate the serial number of your grill by looking at the label attached to the back of the cabinet.

Place  
Postage  
Stamp  
Here

WARRANTY REGISTRATION

BBQ PRO GRILLS

1375 MITCHELL BLVD.

SCHAUMBURG, IL 60193